

Washington Consumer's Guide

Solar Electric Systems

Adapted for Washington by Mike Nelson

Are you thinking about buying a solar electric system for your home or business?

If so, this booklet will provide basic information that you need to know are showing increased interest in solar electric systems for their homes and businesses. These solar electric systems are reliable, pollution free, and use a renewable source of energy—the sun. They are becoming more affordable all the time. And remember: The more energy-efficient your house, the greater the impact of a solar electric system. Measures such as increased insulation and energy-efficient lighting, appliances, and windows will drastically reduce your home's use of electricity.



Several Washington Public Utilities, Electrical Cooperatives and Municipal Utilities have formed a Cooperative - WesternSUN to purchase pre-engineered solar electric systems directly from manufacturers at considerable savings that are passed on to their customers. This helps assure high quality at favorable pricing.

Washington utilities offer net metering to make solar electric systems even

more economical. Net metering means that when your solar electric system generates more power than you need, the meter runs backwards resulting in an even swap for the grid power that you use at other times. In essence, you receive full retail value for all the power that your solar electric system generates.

This booklet is designed to guide you through the process of buying a solar electric system. A word of caution: This is not a technical guide for designing or installing your system—for that information, we recommend that you contact your utility or consult an experienced solar electric system designer or system supplier (“solar electric provider”) who will have detailed technical specifications and other necessary information. A solar electric system can be a substantial investment, and as with any investment, careful planning will help ensure that you make the right decisions.

Background

What is a solar electric system?

Solar electric technology converts sunlight directly into electricity. It works any time the sun is shining, but more electricity will be produced when the light is more intense (a sunny day) and is striking the solar electric modules directly (when the rays of sunlight are perpendicular to the

You don't need to understand the detailed physics of how solar electric works to understand its appeal: investing in solar electric allows you to produce your own electricity with no noise, no air pollution, and no moving parts while using a clean, renewable resource. A solar electric system will never run out of fuel, and it won't increase our oil imports from overseas. In fact, it may not even contribute to the trade deficit, because many solar electric system components are manufactured in the United States. Due to these unique characteristics, solar electric technology has been called "the ultimate energy source for the 21st century."

solar electric modules). Unlike solar systems for heating water, which you might be more familiar with, solar electric technology does not use the sun's heat to make electricity. Instead, solar electric produces electricity directly from the electrons freed by the interaction of sunlight with semiconductor materials in the solar electric cells.

The basic building block of solar electric technology is the solar "cell." solar electric cells are wired together to produce a solar electric "module," the smallest solar electric component sold commercially, and these modules range in power output from about 10 watts to 300 watts. A solar electric system tied to the utility grid consists of one or more solar electric modules connected to an inverter. The inverter changes the system's direct-current (DC) electricity to alternating current (AC), which is compatible with the utility grid and able to power devices such

as lights, appliances, computers, and televisions. You may include batteries in the system to provide back-up power in case your utility experiences a power outage.

Before you decide to buy a solar electric system, you should understand the current status of the technology:

First, it produces power intermittently because it works only when the sun is shining. This is not a problem for solar electric systems connected to the utility grid, because additional electricity you need is automatically delivered to you by your utility.

Second, if you live near existing electrical service, Solar electricity is usually more expensive than conventional utility-supplied electricity. Improved manufacturing has reduced the cost to less than one percent of what it was in the 1970s, but the cost (amortized over the life of the system) is still about 25 cents per kilowatt-hour. This is about two to five times the retail price that residents now pay for electricity from their utilities. A solar rebate program and net metering can help make solar electric more affordable, but it can't match today's price for electricity from your utility, unless of course your building site is more than a quarter mile from the power grid.

Finally, unlike electricity purchased month by month from a utility, solar electric power comes with a high initial investment and no monthly charge thereafter. This means that buying a solar electric system is like paying years of electric bills up front. You'll probably appreciate the reduction in your monthly electric bills, but the initial expense may be significant. By financing your solar electric system, you can spread the cost over many years, and rebates or utility discounts can also lighten your load.

A typical solar electric system and components

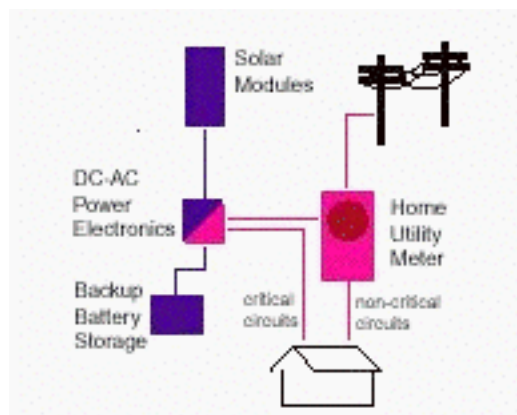

(From Astropower)

Are incentives available to help reduce the cost?

Net Metering—Customers who own solar electric systems can benefit from laws and regulations that require “net” electric meter reading. The customer is billed for the “net” electricity purchased from the utility over the entire billing period—that is, the difference between the electricity coming from the power grid and the electricity generated by the solar electric system. Hence, the monthly reading indicates net customer usage. Through net metering, the customer obtains the full retail electricity rate—rather than the much lower wholesale rate—for kilowatt-hours of-produced electricity sent back to the utility power grid. The consumer benefits of net metering are especially significant in areas such as Hawaii and New York, which have high retail rates. Utilities also benefit because the solar-generated energy often coincides with their peak demand.

Taxes — The U.S. government also provides financial support for solar electric technology through a tax credit for commercial uses of solar energy. This energy investment credit provides businesses (but not individuals or utilities) with a 10% tax credit and 5-year accelerated depreciation for the cost of equipment used to generate electricity by solar technologies.

Investing in a solar electric system

Why should I buy a solar electric system?

People decide to buy solar electric systems for a variety of reasons. Some want to help preserve the earth's finite fossil-fuel resources and reduce air pollution. Others would rather spend their



money on an energy-producing improvement to their property than to send their money to a utility. Some people like the security of reducing the amount of electricity they buy from their utility, because it makes them less vulnerable

to future increases in the price of electricity. Finally, some people just don't like paying utility bills and appreciate the independence that a solar electric system provides.

If you plan to build away from established utility service, you should consider the cost of installing a utility line needed to provide power. Often, the cost of extending conventional power to your residence is more expensive than the solar option.

Whatever your reason, solar energy is widely thought to be the energy source of choice for the future.

Is my home or business a good place for a solar system?

Is your site free from shading by trees, nearby buildings, or other obstructions?

To make the best use of your solar electric system, the solar electric modules must have a clear “view” of the sun for most or all of the day—unobstructed by trees, roof gables, chimneys, buildings, and other features of your home and the surrounding landscape. Note that even though the area where a system is mounted may be unshaded during one part of the day, it may be shaded during another. If this is the case, then this shading may substantially reduce the amount of electricity that your system will produce. To be eligible for some rebates, your system must be unshaded between certain hours during certain times of the year. Some states have laws that establish your right to protect your solar access through the creation of a “solar easement.”



To conduct a solar site survey:

You will need:

A. Angle Gauge

B. Compass

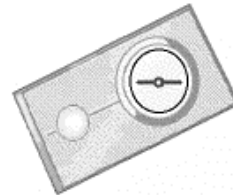

3. Solar site survey chart

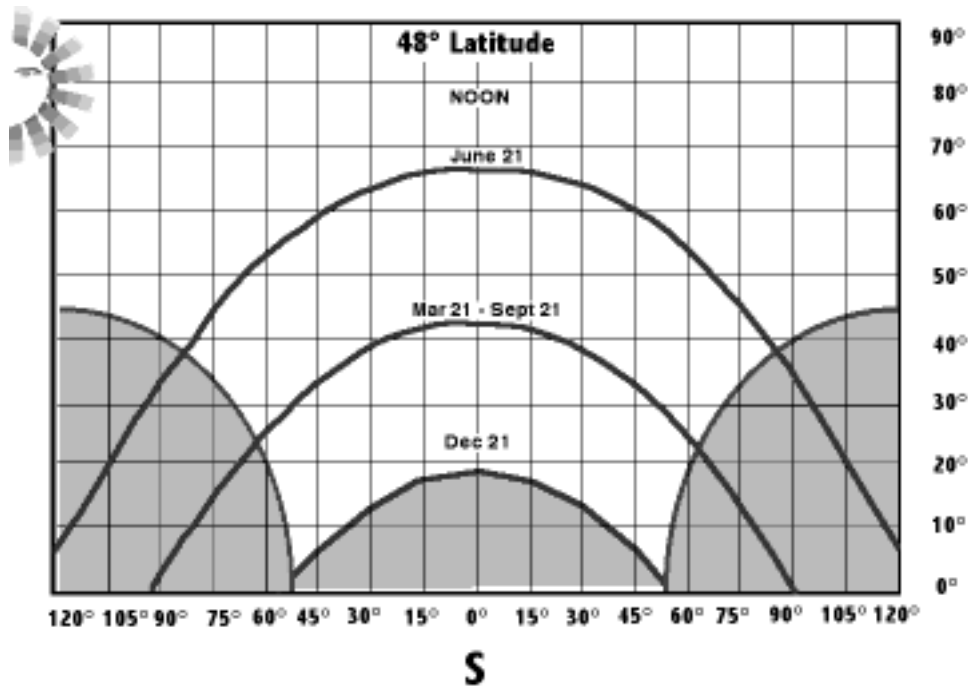

1. The goal of this exercise is to plot the southern skyline at your site.
2. Use the compass to find true south. Make certain that you compensate for magnetic deviation. (Deviation is about 22° E. in most of Washington.)
3. After locating true south, use the angle gauge to site on the top of the highest object or horizon, mark it on a copy of the skychart.

- 4. Repeat the process with each tree, building or other obstruction. If any objects fall in the white zone of the chart, you have problems with your site and should consult a professional before purchasing solar equipment.*

A well-designed solar electric system needs clear and unobstructed access to the sun's rays for most or all of the day, throughout the year. You can make an initial assessment yourself, and if the location looks promising, your solar electric provider has the tools to trace the sun's path at your location and determine whether your home or business can make use of a solar electric solar system.

The orientation of your solar electric system (the compass direction that your system faces) will affect performance. In the United States, the sun is always in the southern half of the sky and is higher in the summer and lower in the winter. Usually, the best location for a solar electric system is a south-facing roof, but roofs that face east or west may also be acceptable. Flat roofs also work well for solar systems because the solar electric modules can be mounted flat on the roof facing the sky or mounted on frames tilted toward the south at the optimal angle.

If a rooftop can't be used, your solar modules can also be placed on the ground, either on a fixed mount or a "tracking" mount that follows the sun to orient the solar electric modules for maximum performance. Other options (used most often in multifamily or commercial applications) include mounting structures that create covered parking or provide shade as window awnings.

Do you have enough area on your roof or property?

The amount of space needed by a solar electric system is based on the physical size of the system you purchase. Most residential systems require as little as 50 square feet (for a small "starter" system) up to as much as 1,000 square feet. Commercial systems are typically even larger. If your location limits the physical size of your system, you may want to install a system that uses more-efficient solar electric modules. Greater efficiency means that the module uses less surface area to convert sunlight into a given amount of electric power. Solar electric modules are available today in a range of types, and some offer more efficiency per square foot than do others. The cost per kilowatt of higher-efficiency modules is about the same as low-efficiency modules, so this may not add to your system's price. System sizing is discussed later in this booklet and should also be discussed with your solar electric provider.

What kind of roof do you have, and what is its condition?

Some roof types are simpler and cheaper to work with, but a solar electric system can be installed on any type. Typically, composition shingles are easiest to work with, and slate is the most difficult. In any case, an experienced solar installer will know how to work on all roof types and can use roofing techniques that eliminate any possibility of leaks. Ask your solar electric provider how the solar electric system affects your roof warranty.

If your roof is older and needs to be replaced in the very near future, you may want to replace it at the time the solar electric system is installed to avoid the cost of removing and reinstalling your solar electric system. Panels often can be integrated into the roof itself, and some modules are actually designed as three-tab shingles or raised-seam metal roof sections. One benefit of these systems is their ability to offset the cost of roof materials.

How big should my solar electric system be, and what features should it have?

As a starting point, you might consider how much of your present electricity needs you would like to meet with your solar electric system. For example, suppose that you would like to meet 50 percent of your electricity needs with your solar electric system. You could work with your solar electric provider to examine past electric bills and determine the size of the solar electric system needed to achieve that goal.

You can contact your utility and request the total electricity usage, measured in kilowatt-hours, for your household or business over the last 12 months (or consult your electric bills if you save them). Ask your solar electric provider how much your new solar electric system will produce on an annual basis (also measured in kilowatt-hours) and compare that number to your annual electricity demand to get an idea of how much you will save.

To qualify for “net metering”, your solar electric system must have a peak generating capacity of not more than typically 25 kilowatts (25,000 watts)

One optional feature you might consider is a battery system to provide back-up power in case of a utility power outage. Batteries add value to your system, but at an increased price.

As you size your system, you should consider the “economies of scale” that can decrease the cost *per kilowatt-hour* as you increase the size of the system. For example, many inverters are sized for systems up to 2.5 kilowatts, and if your solar electric array is smaller (say 1 kilowatt), you may still end up buying the same inverter. Labor costs for a small system may be nearly as much as those for a large system. Therefore, it's worth remembering that your solar electric provider is likely to offer you a better price to install a 2-kilowatt system all at once, than to install a 1-kilowatt this year and another similar system next year-because multiple orders and multiple site visits are more expensive.

How much will my solar electric system save me?

The value of your solar electric system's electricity will depend on how much you pay your utility for electricity and how much your utility will pay you for any excess that you generate. If your utility offers net metering (and so pays the full retail price for your excess electricity), your calculation may be fairly easy because you and your utility will each pay the same price for each other's electricity. You can use the calculation box to roughly approximate how much electricity your solar electric system will produce and how much that electricity will be worth. Keep in mind that actual energy production from your solar electric system will vary by up to 20 percent from these figures, depending on your geographic location, the angle and orientation of your system,

the quality of the components of your system, and the quality of the installation. Also keep in mind that you may not get full retail value for excess electricity produced by your system on an annual basis, even if your utility does offer net metering. Be sure to discuss these issues with your solar electric provider. Consider asking for a written estimate of the average annual energy production from the solar electric system. However, you should realize that even if an estimate is accurate for an average year, actual electricity production will fluctuate from year to year due to natural variations in weather and climate.

If your utility does not offer net metering, you can still use the calculation box to determine the amount of electricity your system will produce. But determining its value is much trickier because your excess electricity will not be worth as much as the electricity you actually use. You may earn only 2 cents per kilowatt-hour—or less than half of the retail rate—for your excess power. Solar electric systems produce most of their electricity during the middle of the day when residential electric loads tend to be small. If net metering is not offered by your utility, you may want to size your system to avoid generating electricity significantly beyond your actual needs.

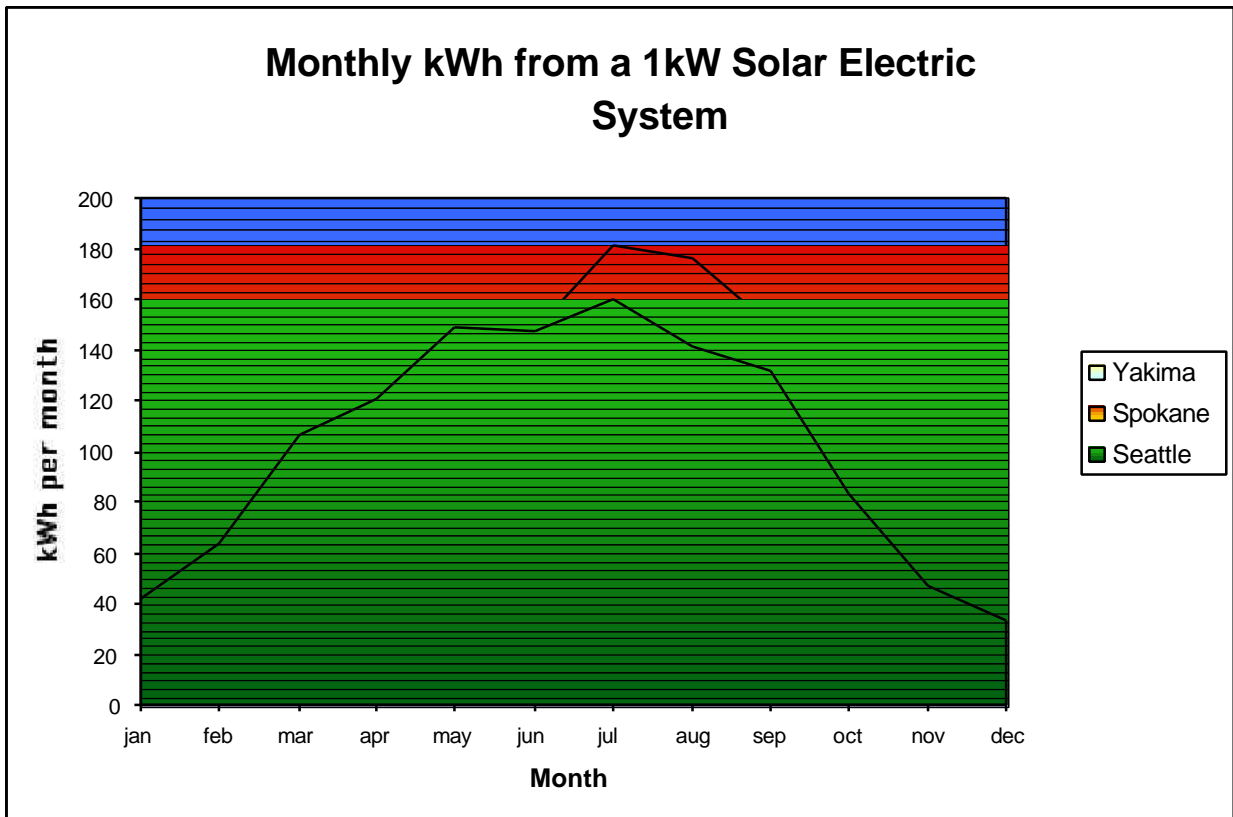

Calculating Electricity Bill Savings for a Net-Metered solar electric System

- Determine the system's size in kilowatts (kW). A reasonable range is 1 to 2 kW. This value is the "**kW of SOLAR ELECTRIC**" input for the formulas below.
- Based on your geographic location, select the energy production factor from the map below for the "**Average Annual Daily Radiation**" input for the equations.
- **Energy from the solar electric system = (kW of SOLAR ELECTRIC) x (the "Average Annual Daily Radiation) x 365 = kWh/year**
- **Energy bills savings = (kWh/year) x (Residential Rate) / 100 = \$/year saved**

(Residential Rate in the above formula should be in dollars per kWh; for example, a rate of 10 cents per kWh is input as \$0.10/kWh.)

For example, a 2-kW system in Bellevue, WA, at a residential energy rate of \$0.07/kWh will save about \$ 180 per year (3.5 annual daily radiation x 365 x 2 kW x \$0.07 = \$266/year).

Average Annual Daily Radiation - kWh/m²

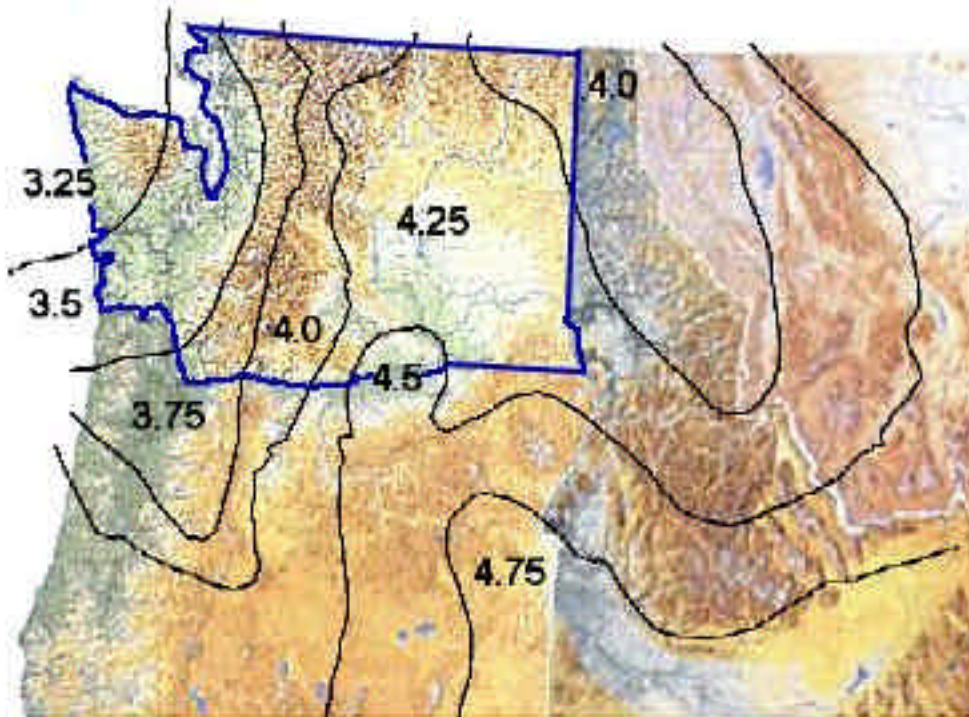

How much does a solar electric system cost?

Your system's price will depend on a number of factors, including whether the home is under construction or whether the solar electric is integrated into the roof or mounted on top of an existing roof. The price also varies depending on the solar electric system rating, manufacturer, retailer, and installer.

The *size* of your system may be the most significant factor in any equation measuring your costs against your benefits. Small, single SOLAR ELECTRIC-panel systems with built-in inverters that produce about 75 watts may cost around \$900 installed, or \$12 per watt. These small systems will offset only a small fraction of your electricity bill. A 2-kilowatt system that will offset the needs of a very energy-efficient home may cost \$12,000 to \$20,000 installed, or \$6 to \$10 per watt. These prices, of course, are just rough estimates, and your costs will depend on your system's configuration, your equipment options, and other factors. Your local solar electric providers can provide you with estimates or bids.

How can I finance the cost of my solar electric system?

There is nothing magical about financing the cost of purchasing and installing your solar electric system. Although there are some special programs available for financing solar and other renewable-energy investments, most of the options will be familiar to you.

The best way to finance solar electric systems for homes is through a mortgage loan. Mortgage financing options include your primary mortgage, a second mortgage such as a U.S. Department of Housing and Urban Development (HUD) Title 1 loan, or a home-equity loan that is secured by your property. There are two advantages to mortgage financing. First, mortgage financing usually provides longer terms and lower interest rates than other loans such as conventional bank loans. Second, the interest paid on a mortgage loan is generally deductible on your federal taxes (subject to certain conditions). If you buy the solar electric system at the same time that you build, buy, or refinance the house on which the solar electric system will be installed, adding the cost of the solar electric system to your mortgage loan is likely to be relatively simple and may avoid additional loan application forms or fees.

If mortgage financing is not available, look for other sources of financing, such as conventional bank loans. Remember to look for the best possible combination of low rate and long term. This will allow you to amortize your solar electric system as inexpensively as possible. Because your solar electric system is a long-term investment, the terms and conditions of your solar electric financing are likely to be the most important factor in determining the effective price of your SOLAR ELECTRIC-generated power.

Solar electric systems purchased for business applications are probably best financed through a company's existing sources of funds for capital purchases—usually Small Business Administration loans or conventional bank loans.

Selecting a solar electric installer

Who sells and installs solar electric systems?

In some locations, finding a solar electric provider can be as simple as picking up the telephone directory and looking under “Solar Energy Equipment and Systems—Dealers.” Be aware, however, that many of those listings are for solar water-heating companies. Many of these companies may not be experienced in solar electric system design or installation. Similarly, many electrical contractors, although proficient in typical electrical contracting work, may not have expertise in solar electric or with residential roof-mounting techniques. *How do you identify solar electric system providers?* Here are several suggestions.

Check the Directory of the U.S. Solar Electric Industry, which is posted at the following Web address:
<http://www.eren.doe.gov/solarelectric/solarelectricdirectory.html>

- Contact the Solar Energy Industries Association for a list of solar service providers (202-383-2600).
- Contact your utility company to see which vendors it might recommend.
- Conduct a search on the Internet.

Unless you are skilled in solar electric installation, you should consider hiring a reputable professional contractor with experience in installing solar electric systems.

How do I choose among solar electric providers?

Compile a list of prospective solar electric providers. You might first consider those closest to you, because the contractors travel costs might add to your system price. Next, contact these providers and find out what products and services they offer. The following questions may give you a good sense of their capabilities:

Has the company installed grid-connected solar electric systems? If not, has it installed grid-independent solar electric systems?

Experience installing grid-connected systems is valuable because some elements of the installation—particularly interconnection with the local utility—are unique to these systems. Because grid-connected systems are relatively uncommon, most contractors with solar electric experience have worked only on systems such as those that power remote cabins far from the nearest utility line. This means they have experience with all aspects of solar electric system installation *except* the connection with the utility grid. Although grid-connection work is different from “off-grid” work, a competent company with solar electric experience should not be eliminated just because it has not installed grid-connected solar electric systems in the past. In fact, experience with off-grid systems is valuable because grid-independent systems are more technically complicated than grid-tied systems.

How many years of experience does the company have installing solar electric systems?

This issue speaks for itself: A company or contractor that has been in business a long time has demonstrated an ability to work with customers and to compete effectively with other firms.

Is the company properly licensed?

Solar electric systems should be installed by an appropriately licensed contractor. This usually means that either the installer or a subcontractor has an electrical contractor's license. Your State Electrical Board can tell you if a contractor has a valid electrician's license. Local building departments also may require that the installer have a general contractor's license. Consumers should call the city and county in which they live for additional information on licensing.

A solar rebate program may require that, in addition to being properly licensed, installers must demonstrate that they possess special knowledge about installing solar electric systems. This special knowledge may be demonstrated in one of the following ways:

- Possession of a solar contractor specialty license, issued by a local building jurisdiction, that recognizes—through testing or other means—special knowledge of solar electric systems.
- Certification in solar electric systems by a group such as the state chapter of SEIA.

- A letter from the manufacturer of the solar electric system stating that the installer has experience and/or training necessary to install the system properly.

Does the company have any pending or active judgements or liens against it?

As with any project that requires a contractor, due diligence is recommended. The Washington State Electrical Board at the Department of Labor and Industries can tell you about any judgments or complaints against a state-licensed electrician. Consumers should call the city and county in which they live for additional information on how to check up on contractors. The Better Business Bureau is another source of information on contractors.

How do I choose among competing bids?

If you have decided to get more than one bid for the installation of your solar electric system (and it's generally a good idea to do so), you should take steps to ensure that all of the bids you receive are made on the same basis. For example, comparing a bid for a system mounted on the ground against another bid for a rooftop system is like comparing apples to oranges. Similarly, different types of solar electric modules generate more electricity per square foot than others. Bids should clearly state the maximum generating capacity of the system (measured in watts or kilowatts). If possible, have the bids specify the system capacity in “AC watts” under a standard set of test conditions, or specify the output of the system at the inverter.

You may want to obtain some estimate of the amount of energy that the system will produce on an annual basis (measured in kilowatt-hours). Because the amount of energy depends on the amount of sunlight—which varies by location, season, and year to year—it is unrealistic to expect a specific figure. A range of $\pm 20\%$ is more realistic. Bids also should include the total cost of getting the solar electric system up and running, including hardware, installation, connection to the grid, permitting, sales tax, and *warranty*.

Your warranty is a very important factor for evaluating bids. A solar rebate program may require that systems be covered by, say, a two-year parts-and-labor written installation warranty, in addition to any manufacturers' warranties on specific components. The installer may offer longer warranties. Also ask yourself, “Will this company stand behind the full-system warranty for the next two years?”

Is the lowest price the “best deal”?

It might not be. Often, you get what you pay for. Remember that a solar electric company is a business just like any other, with overhead and operating expenses that must be covered. It's always possible that a low price could be a sign of inexperience. Companies that plan to stay in

business must charge enough for their products and services to cover their costs, plus a fair profit margin. Therefore, price should not be your only consideration.

Before connecting a solar electric system to the grid

What about permits?

If you live in a community in which a homeowners association requires approval for a solar system, you or your solar electric provider may need to submit your plans. Gain approval from your homeowners association before you begin installing your solar electric system. Under the law in some states, you have the right to install a solar system on your home.

Most likely, you will need to obtain permits from your city or county building department. You will probably need a building permit, an electrical permit, or both before installing a solar electric system. Typically, your solar electric provider will take care of this, rolling the price of the permits into the overall system price. However, in some cases, your solar electric provider may not know how much time or money will be involved in “pulling” a permit. If so, this task may be priced on a time-and-materials basis, particularly if additional drawings or calculations must be provided to the permitting agency. In any case, make sure the permitting costs and responsibilities are addressed at the start with your solar electric provider.

Code requirements for solar electric systems vary somewhat from one jurisdiction to the next, but most requirements are based on the National Electrical Code (NEC). The NEC has a special section, Article 690, that carefully spells out requirements for designing and installing safe, reliable, code-compliant solar electric systems. Because most local requirements are based on the NEC, your building inspector is likely to rely on Article 690 for guidance in determining whether your solar electric system has been properly designed and installed. If you are among the first people in your community to install a grid-connected solar electric system, your local building department may not have approved one of these systems. If this is the case, you and your solar electric provider can speed the process by working closely and cooperatively with your local building officials to help educate them about the technology and its characteristics.

What about insurance?

Your electric utility will require you to enter into an interconnection agreement, described more fully in the next section. Usually, these agreements set forth minimum insurance requirements that you must keep in force. If you are buying a solar electric system for your home, your standard homeowner’s insurance policy is usually adequate to meet the utility’s requirements. However, if insurance coverage becomes an issue, contact one of the groups under Getting Help at the end of this booklet.

How do I get an interconnection agreement?

Connecting your solar electric system to the utility grid will require you to enter into an interconnection agreement and a purchase and sale agreement. Federal law and perhaps your state's public utility commission regulations require utilities to supply you with an interconnection agreement. Some utilities have developed simplified, standardized interconnection agreements for small-scale solar electric systems.

The interconnection agreement specifies the terms and conditions under which your system will be connected to the utility grid. These will include your obligation to obtain permits and insurance, maintain the system in good working order, and operate it safely. The purchase and sale agreement specifies the metering arrangements, the payment for any excess generation, and any other related issues.

The language in these contracts should be simple, straightforward, and easy to understand. If you are unclear about your obligations under these agreements, you should contact the utility or your electrical service provider for clarification. If your questions are not adequately addressed, contact one of the groups under Getting Help at the end of this booklet.

National standards for utility interconnection of solar electric systems are quickly being adopted by many local utilities. The most important of these standards focuses on inverters. Traditionally, inverters simply converted the DC electricity generated by solar electric modules into the AC electricity used in our homes. More recently, inverters have evolved into remarkably sophisticated devices to manage and condition power. Many new inverters contain all the protective relays, disconnects, and other components necessary to meet the most stringent national standards. Two of these standards are particularly relevant:

- Institute of Electrical and Electronic Engineers, *P929: Recommended Practice for Utility Interface of Solar electric Systems*. Institute of Electrical and Electronic Engineers, Inc., New York, NY (1998).
- Underwriters Laboratories, *UL Subject 1741: Standard for Static Inverters and Charge Controllers for Use in Solar electric Power Systems* (First Edition). Underwriters Laboratories, Inc., Northbrook, IL (December 1997).

You don't need to fully understand these standards, but your solar electric provider and utility should. It is your obligation to ensure that your solar electric provider uses equipment that complies with the relevant standards, so be sure to discuss this issue.

How do I get a net-metering agreement?

Some utilities offer customers with solar electric systems the option to “net meter” the excess power generated by the solar electric system. This means that when the solar electric system generates more power than the household can use, the utility pays the full retail price for this power in an even swap as the electric meter spins backward.

Net metering allows eligible customers with solar electric systems to connect to the grid with their existing single meter. Almost all standard utility meters are able to measure the flow of energy in either direction. The meter spins *forward* when electricity is flowing from the utility into the building and spins *backward* when power is flowing from the building to the utility. For example, in one utility program, customers are billed monthly for the “net” energy consumed. If the customer’s net consumption is negative in any month (i.e., the solar electric system produces more energy than the customer uses), the balance is credited to subsequent months. At the end of the year, excess power is ceded to the utility. Some utilities will pay the homeowner for solar power or allow the home owner to carry power credit into the spring.

Net metering allows customers to get more value from the energy they generate. It also simplifies both the metering process (by eliminating the need for a second meter) and the accounting process (by eliminating the need for monthly payments from your utility). Be sure to ask your utility about its policy regarding net metering.

Under the federal Public Utility Regulatory Policies Act (PURPA), utilities must allow you to interconnect your solar electric system, and they must also buy any excess electricity you generate (beyond what you use in your home or business). If your utility does not offer net metering, it will probably require you to use two meters: one to measure the flow of electricity *into* the building, the other to measure the flow of electricity *out of* the building. If net metering is not available, the utility will only pay you a *wholesale* rate for your excess electricity. In this case, you will have a strong incentive to use all the electricity you generate so that it offsets electricity you would otherwise have to purchase at the *retail* rate. This may be a factor in how you optimize your system size, because you may want to limit the excess electricity you generate. This “dual metering” arrangement is the norm for industrial customers who generate their own power.

What about utility and inspection sign-off?

After your new solar electric system is installed, it must be inspected and “signed off” by the local permitting agency (usually a building or electrical inspector) and most likely by the electric utility with which you entered into an interconnection agreement. Inspectors may possibly require your solar electric provider to make corrections, but don’t be alarmed—this is fairly

common in the construction business. A copy of the building permit showing final inspection sign-off may be required to qualify for a solar rebate program.

What about warranties?

Warranties are key to ensuring that your solar electric system will be repaired if something should malfunction during the warranty period. Solar electric systems eligible for some solar rebate programs must carry a full (not “limited”) two-year warranty, in addition to any manufacturers’ warranties on specific components. This warranty should cover all parts and labor, including the cost of removing any defective component, shipping it to the manufacturer, and reinstalling the component after it is repaired or replaced. The rebate program’s two-year warranty requirement supercedes any other warranty limitations. In other words, even if the manufacturers own warranty on a particular component is less than two years, the system vendor must still provide you with a two-year warranty. Similarly, even if the manufacturer’s warranty is a limited warranty that does not include the cost of removing, shipping, and reinstalling defective components, the system vendor must cover these costs if the retailer also installed the system.

Be sure you know who is responsible for honoring the various warranties associated with your system—the installer, the dealer, or the manufacturer. The vendor should disclose the warranty responsibility of each party. Know the financial arrangements, such as contractor’s bonds, that assure the warranty will be honored. Remember that a warranty does not guarantee that the company will remain in business. Get a clear understanding of whom you should contact if there is a problem. Under some solar rebate programs, vendors must provide documentation that specifies information on system and component warranty coverage and claims procedures. To avoid any later misunderstandings, be sure to read the warranty carefully and review the terms and conditions with your retailer.

Getting help

To get more information on solar electric systems, please contact:

Your local Public Utility, Electric Cooperative, or Municipal Electric Utility

Or:

www.westernsun.com

Or:

Solar Energy Industries Association (SEIA)

122 C Street, NW

4th Floor

Washington, DC 20001-2109

Fax: (202) 363-2670

<http://www.seia.org>

The Solar Energy Industries Association is the national trade association of the solar industry.

Other Web Sites to Check

www.nrel.gov/ncsolar_electric

www.eren.doe.gov/millionroofs

www-solar.mck.ncsu.edu/dsire.htm

Adapted by Mike Nelson from a document produced by Tom Starrs for:
U.S Department of Energy
1000 Independence Ave., S.W.
Washington, D.C. 20585
National Renewable Energy Laboratory,
A DOE national laboratory.

September 2000